

Measurement of Fluid Film Thickness on The Valve Plate in Oil Hydraulic Axial Piston Pumps (Part II : Spherical Design Effects)

Jong-Ki Kim*, Hyoung-Eui Kim, Yong-Bum Lee

Korea Institute of Machinery & Materials, 171 Jang-dong, Yuseong-Gu,
Daejeon 305-600, Korea

Jae-Youn Jung

Faculty of Mechanical & Aerospace System Engineering, Chonbuk National University,
Jeonju, Jeonbuk 561-756, Korea

Seok-Hyung Oh

Faculty of Mechanical Engineering, Kunsan National University,
Kunsan, Jeonbuk 573-701, Korea

Tribological characteristics in the sliding parts of oil hydraulic piston pumps are very important in increasing overall efficiency. In this study, the fluid film between the valve plate and the cylinder block was measured by using a gap sensor and the mercury-cell slip ring unit under real working conditions. To investigate the effect of the valve shape, we designed three valve plates each having a different shape. One of the valve plates was without bearing pad, another valve plate had bearing pad and the last valve plate was a spherical valve plate. It was noted that these three valve plates observed different aspects of the fluid film characteristics between the cylinder block and the valve plate. The leakage flow rates and the shaft torque were also investigated in order to clarify the performance difference between these three types of valve plates. From the results of this study, we found that the spherical valve plate estimated good fluid film patterns and good performance more than the other valve plates in oil hydraulic axial piston pumps.

Key Words : Hydraulic Axial Piston Pump, Fluid Film, Valve Plate, Cylinder Block

Nomenclature

D_p	Piston diameter
F_1	Pushing force between valve plate and cylinder block
F_2	Separating force between valve plate and cylinder block
h	Fluid film thickness on valve plate
h_{min}	Minimum fluid film thickness on valve plate

N	Number of piston
P_d	Discharge pressure in pump
ΔQ	Leakage flow rates on valve plate
α	Tilting angle of cylinder block
μ	Viscosity of working oil
$r_1 \sim r_4$	Radius of seal land on valve plate

1. Introduction

Despite the fact that the oil hydraulic axial piston pumps are more expensive than other types of pump, the use of the oil hydraulic axial piston pumps is rapidly increasing due to the variable discharge characteristics, higher working pressures, higher volumetric and overall efficiencies

* Corresponding Author,
E-mail bellflag@kimm.re.kr
TEL +82-42-868-7163 FAX +82-42-868-7186
Korea Institute of Machinery & Materials, 171 Jang-dong, Yuseong-Gu, Daejeon 305-600, Korea (Manuscript Received March 6, 2004, Revised December 3, 2004)

Oil hydraulic axial piston pumps have been used to the heavily demanding operational conditions which often lead to the tribological problems of the sliding parts. The interface between valve plate and cylinder block is the most important sliding part in axial piston pumps, because the cylinder block rapidly rotates on the fixed valve plate, and the pistons in cylinders during approximately half a revolution perform the suction and the discharge action of working oil through the kidney ports. Also, the pressure distribution on the valve plate varies momentarily, and optimal force balance is required to reduce the leakage flow rates and friction.

Many researches have been carried out to improve the pump design. Saichenko (1950) described the various forces acting on the cylinder block without going into detail on the nature of those at the interface with the valve plate. Franco (1961) derived the sealing land hydrostatic pressure's radial variation for points away from the valve port ends but no account of the pressure field between the two ports of the valve plate. The most extensive work was that of Shute and Turnbull (1964). In addition, McKewon et al (1966) addressed an extensive survey for various inventions relating to these machines, some of which are concerned with certain valve plate design techniques. Furthermore, good studies have been accomplished on the principles of the force balancing between the cylinder block and the valve plate (Hrbbeit et al, 1971, Taylor and Lin, 1984, Jung et al, 2003, Kim et al, 2004). However, fluid film on the valve plate in oil hydraulic axial piston pumps have not been revealed in detail, because of the difficulties involved in measuring the fluid film. The continuous measurement of the fluid film on the valve plate in driving conditions is extremely difficult due to the very high rotational speed of the cylinder block.

In the present study, the fluid film between valve plate and cylinder block was measured by using a gap sensor and a slip ring system under dynamic conditions in order to seek the tribological analysis and the design criterion of the valve plate in more detail.

2. Force Balance and Fluid Film on Valve Plate

There are two principal axial forces acting on the bearing surface between valve plate and cylinder block. One of these forces is a pushing force associated with highly pressurized pistons tending to push the cylinder block to the valve plate. And the other is a separating force associated with the pressure in the highly pressurized kidney port and across its lands tending to separate the cylinder block with the valve plate. If the pushing force due to the pistons under high pressure is too big, the faces will be subjected to high friction, rapid wear, overheating, and therefore reducing mechanical efficiency. Alternatively, if the separating force due to the pressure distribution on the seal lands is too big, the cylinder block will be forced away from the valve plate leading to excessive leakage losses. It is essential to calculate these two forces as accurately as possible in order to maintain adequate balance between them. Most axial piston pumps have an odd number of pistons to reduce the pulsation of pressurized oil. And since the number of cylinders containing the highly pressurized working oil is half of the total number of pistons, the pushing force can be calculated by the following equation.

$$F_1 = \frac{\pi}{8} D_p^2 P_d N \quad (1)$$

Also, the separating force can be calculated by,

$$F_2 = \frac{\pi}{4} P_d \left\{ \frac{r_4^2 - r_3^2}{\ln(r_4/r_3)} - \frac{r_2^2 - r_1^2}{\ln(r_2/r_1)} \right\} \quad (2)$$

The fluid film on the valve plate is produced by balancing these two forces. Considering the fluid film between the adjacent faces of the cylinder block and the valve plate of the oil hydraulic piston pump (as shown in Fig. 1) if the leakage flow rates is (ΔQ), the mean fluid film (h) will be expressed in the following form.

$$h = \left\{ \frac{12\mu\Delta Q}{\pi P_d} \cdot \frac{\ln(r_2/r_1) \cdot \ln(r_4/r_3)}{\ln(r_2/r_1) + \ln(r_4/r_3)} \right\}^{\frac{1}{3}} \quad (3)$$

As the cylinder block is tilted from the center of

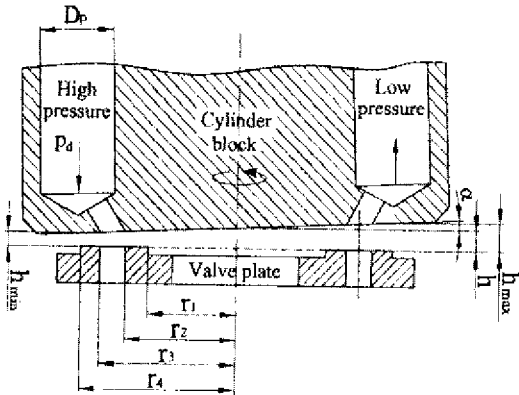

Fig. 1 Fluid film on valve plate

the valve plate, the fluid film in the discharge region being smaller than that in the suction region. This caused an appearance of minimum fluid film on the valve plate in the discharge region. Hence the minimum fluid film (h_{min}) on the valve plate is given by :

$$h_{min} = \left(\frac{12 \mu \Delta Q}{\pi P_d} \cdot \frac{\ln(r_2/r_1) \cdot \ln(r_4/r_3)}{\ln(r_2/r_1) + \ln(r_4/r_3)} \right)^{\frac{1}{3}} - r_4 \sin \alpha \quad (4)$$

3. Experimental Apparatus and Method

The picture of the test cylinder block is shown in Fig. 2. A section diagram of the test piston

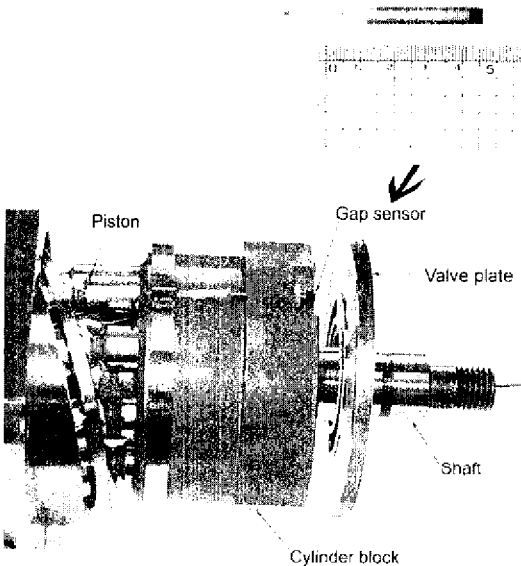

Fig. 2 Picture of test cylinder block

pump is shown in Fig. 3 and the specifications of the test piston pump is shown in Table 1. The miniature gap sensor was mounted in the hole of around the cylinder to continuously measure fluid film thickness during the working period of the test pump. A wire of the gap sensor was led through the center of the shaft and taken out from housing to connect with a slip ring unit. During the rotation of the cylinder block, signals from the gap sensor are transmitted to a recorder via a mercury-cell slip ring unit. A digital oscillographic recorder was used in order to display the gap sensor signals which were permanently stored in the recorder's memory and plotted by some other

Table 1 Specifications of test piston pump

Displacement (cc/rev)	63
Swash plate angle (deg)	18
The number of piston	9
Max. Pressure (MPa)	35
Max. Speed (rpm)	2,500

Table 2 Gap sensor specifications

Measuring Range	0~2 mm
Output Voltage	±5 (10V P-P) V
Input Voltage	±12 V DC
Resolution Voltage	3×10 ⁻⁴ V
Working Temperature	-10~+120°C

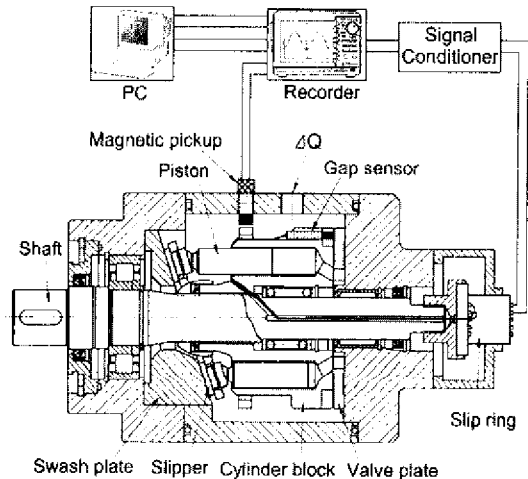

Fig. 3 Schematic diagram of test piston pump

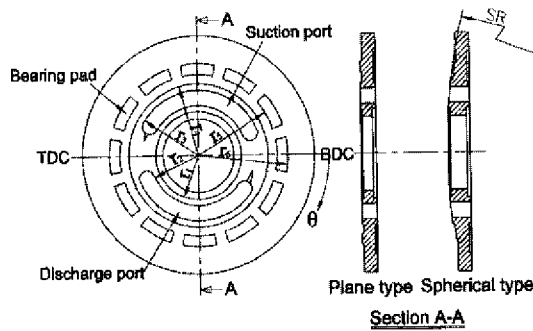

Fig. 4 Shape of test valve plates

graphic means in a personal computer. The specifications of the gap sensor is shown in Table 2.

The shapes of the test valve plates are shown in Fig. 4. Also, specifications of the test valve plates are shown in Table 3. Three valve plates were used in the test. One is the plane valve plate without bearing pad. Another is the plane valve plate with bearing pad and the other is the spherical valve plate. As the drive shaft rotates, the cylinder block slides on the valve plate having two kidney ports. Hence, two forces occur between valve plate and cylinder block. The fluid film between valve plate and cylinder block is generated by these two balancing forces. The signal of miniature gap sensor is continuously produced on the target valve plate under driving conditions.

The arrangement of the hydraulic circuit for this experiment is shown in Fig. 5. The test piston pump was driven by a variable speed electric motor (75 kw). The motor speed was continuously adjusted from 0 to 2,000 rpm by use of a vector inverter controller. The test piston pump was connected with a driving motor by insulating coupling. The torque sensor was mounted in the middle of the test pump and driving motor.

The pressure, flow and temperature sensors were mounted in the discharge line. The relief valve controlled the discharge pressure from 0 to 30 MPa in the test pump. The heat exchanger was used to control oil temperature in the test unit. Furthermore, the filter was mounted in the suction line and the return line so as to maintain the clean working oil.

A broad range of experiments must be con-

Table 3 Specifications of test valve plates

	VP1	VP2	VP3
Type	Plane valve without pad	Plane valve with pad	Spherical valve
r_1 (mm)	24	24	24
r_2 (mm)	27.1	27.1	27.1
r_3 (mm)	35.6	35.6	35.6
r_4 (mm)	39	39	39
r_5 (mm)	—	44	—
r_6 (mm)	—	50	—
SR (mm)	—	—	300

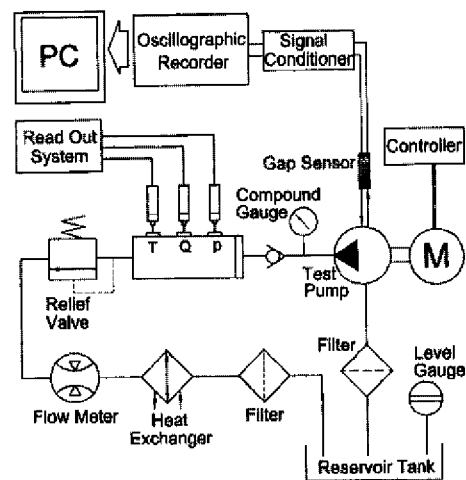

Fig. 5 Hydraulic circuit of test equipment

ducted to provide reasonable data on the effect of fluid film. In this study, the main test conditions which were considered are discharge pressure, rotational speed and valve plate geometry. We acquired many test results such as fluid film, discharge pressure pulsation, leakage flow rates and shaft torque. The range of discharge pressure was 0–30 MPa and the range of rotational speed was 0–1800 rpm. The working oil was ISO VG46 and the oil temperature is controlled not to exceed $40 \pm 2^\circ\text{C}$.

4. Experimental Results

4.1 Fluid film variations with discharge pressure and rotational speed

Figure 6 shows fluid film variations with dis-

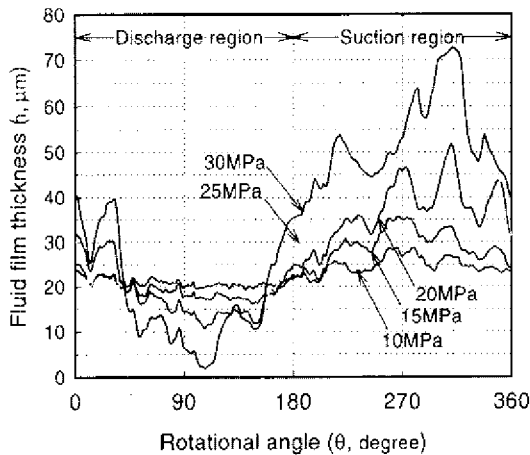

Fig. 6 Fluid film variations on the plane valve plate without bearing pad (VP1)

charge pressure on the plane valve plate without bearing pad during a revolution of the cylinder block at 1,500 rpm. It is found that the several small fluctuations of fluid film are resulted from discharge pressure pulsation produced by nine pistons. The fluid film on the valve plate is continuously changed during one revolution of the cylinder block. It means that the shaking and tilting phenomena of the cylinder block being produced in the driving condition. The shaking of the cylinder block is caused by the discharge pressure pulsation. The tilting of the cylinder block is caused by the clearance of the spline and the bearing. The size of the shaking and the tilting increases with increased discharge pressure. It might be inferred from these phenomena that the change of fluid film will be produced according to the rotation of the cylinder block.

At 10 MPa discharge pressure, the minimum fluid film was measured to be 20 μm but at 30 MPa discharge pressure, the minimum fluid film was measured to be 2 μm which is equivalent to 10 percent of 20 μm . If the direction of the cylinder block is from left to right (in Fig. 6), the associated minimum fluid film exists in the discharge region ($\theta=90-135^\circ$) and the maximum fluid film exists in the suction region. The location of minimum fluid film depends on the balancing forces and the eccentricity of the cylinder block. In case of the plane valve plate

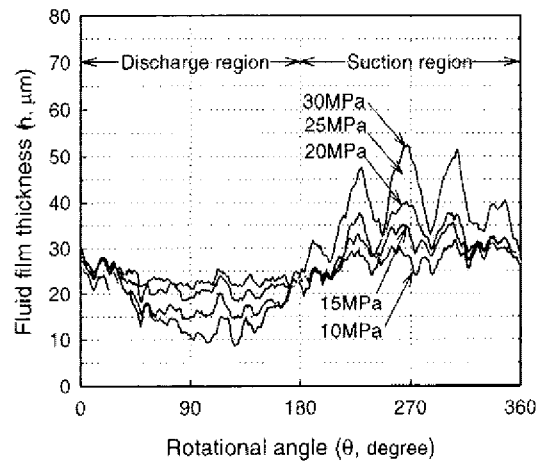

Fig. 7 Fluid film variations on the plane valve plate with bearing pad (VP2)

without bearing pad, the possibility of contacts between valve plate and cylinder block is remarkably increasing in high discharge pressure condition. Therefore, high friction and severe wear will be occurred and the frictional loss will be increased.

The fluid film variations with discharge pressure on the plane valve plate with bearing pad during a revolution of the cylinder block at 1,500 rpm are shown in Fig. 7. At 30 MPa discharge pressure, the minimum fluid film was measured to be 9 μm which is 7 μm higher than the value of the plane valve plate without bearing pad. Because of the hydrodynamic effect at bearing pad, fluid film increased over all test conditions. The difference of fluid film between on discharge region and suction region was reduced compared with that of the plane valve plate without bearing pad (see Fig. 6). Also, the size of the several small fluctuations of fluid film was fairly decreased over the high discharge pressure region above 20 MPa. Therefore, it is clear that the plane valve plate with bearing pad has more desirable fluid film pattern than the plane valve plate without bearing pad at the high discharge pressure region.

The fluid film variations on the spherical valve plate are shown in Fig. 8. At 30 MPa discharge pressure, the minimum fluid film was measured to be 13 which was about 4 higher than the value

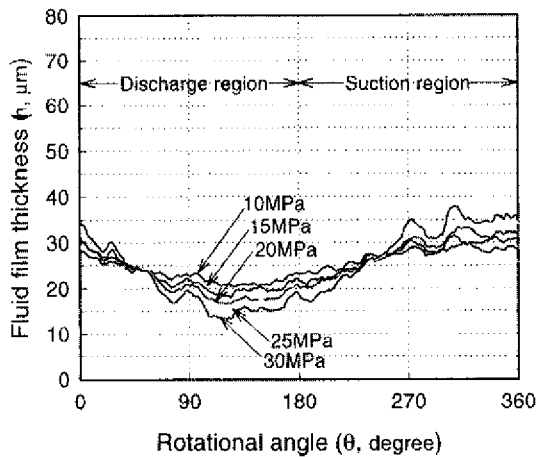

Fig. 8 Fluid film variations on the spherical valve plate (VP3)

of the plane valve plate with bearing pad. The difference of fluid film between discharge region and suction region was remarkably reduced compared with that of the plane valve plate without bearing pad. Also, the size of the several small fluctuations of fluid film was considerably decreased throughout the driving conditions. The changing pattern of the fluid film on the spherical valve plate maintains the most stability among the three test valve plates. This means that the spherical valve plate sustains good tribological condition between valve plate and cylinder block due to the spherical contact.

Figure 9 shows a discharge pressure pulsation at 30 MPa, 1,500 rpm. The general tendency of nine small pulsations was observed. These typical patterns are caused by the number of pistons in a piston pump. The size of pressure pulsation in the spherical valve plate is the smallest among the three valve plates. Also, it was found that the pressure pulsation is deeply related with the contour of fluid film on the valve plate, and the spherical valve plate maintain the most acceptable performance of discharge pressure pulsation.

Figure 10 shows minimum fluid film variations with the rotational speed at 20 MPa. On the whole, the minimum fluid film slightly increased as rotational speed increased. Especially, the spherical valve plate had the most increasing

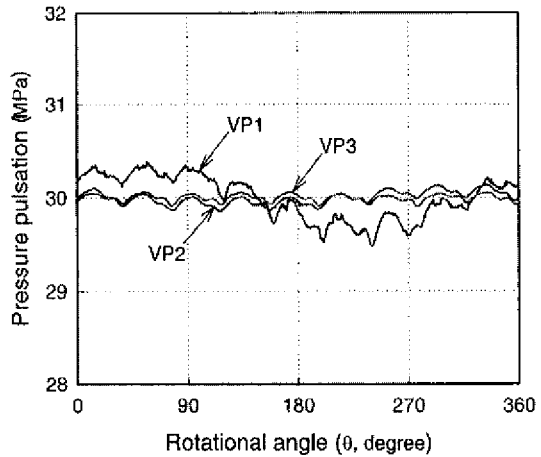

Fig. 9 Comparison of discharge pressure pulsation at 30 MPa

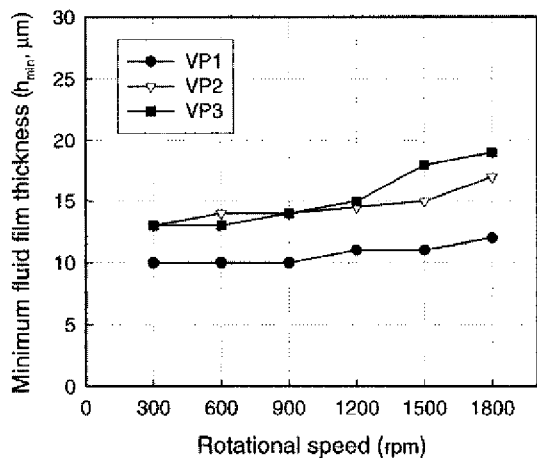

Fig. 10 Minimum fluid film variations with rotational speed at 20 MPa

rate among the three valve plates. In case of the two types plane valve plates had the similar increasing pattern all rotational speed range. The minimum fluid film of the plane valve plate with bearing pad is about $4 \mu\text{m}$ bigger than the plane valve plate without bearing pad over all rotational speed range because of the hydrodynamic action at the bearing pad region.

4.2 Comparison of fluid films

The comparison of fluid film in the three valve plates at 1,500 rpm is shown in Figs. 11 and 12. For lower discharge pressure than 15 MPa,

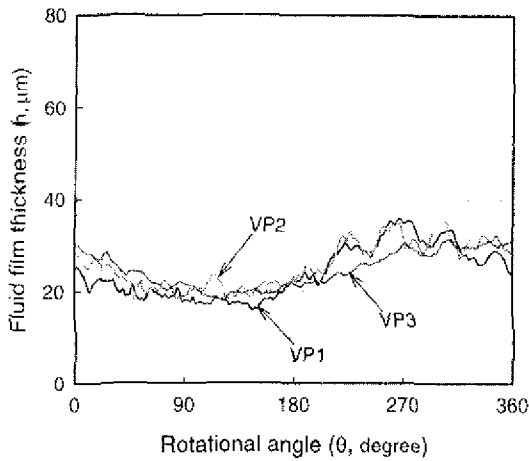

Fig. 11 Comparison of fluid film at 15 MPa

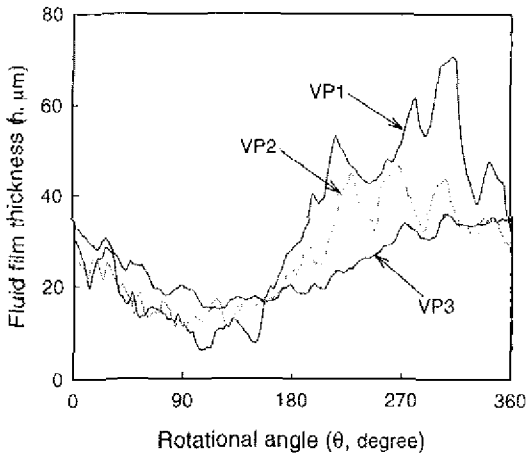

Fig. 12 Comparison of fluid film at 25 MPa

the pattern of fluid film in VP1 and VP2 was almost similar each other. The pattern of fluid film in VP3 shows a smooth profile compared with those of the two valve plates.

For high pressure range of 25 MPa, the pattern of fluid film is considerably different. The pattern of VP1 is the worst of the three valve plates. On the other hand, the pattern of VP3 is the most acceptable of the three valve plates. This difference occurs when the cylinder block was tilted at the high pressure region.

It was found that the stable tribological action of the spherical valve plate could reduce the inclination and the shake of the cylinder block. In the case of the plane valve plate without bearing pad, the inclination of cylinder

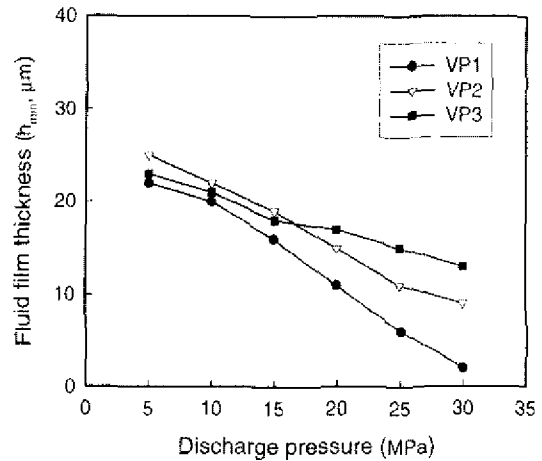

Fig. 13 Comparison of minimum fluid film with discharge pressure

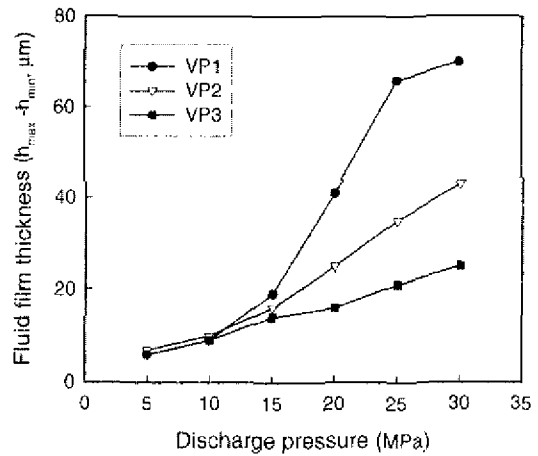

Fig. 14 Difference between maximum and minimum fluid film

block drastically increases and leakage flow rates largely increases for high pressure above 25 MPa.

The effects of discharge pressure on minimum fluid film are shown in Fig. 13. The minimum fluid film linearly decreased as discharge pressure increases. Especially, the minimum fluid film of the plane valve plate without bearing pad decreased more steeply than the other valve plates in high pressure range. For the high pressure range above 20 MPa, the design of bearing pad on the plane valve plate could ensure bigger minimum fluid film from 5 μm to 7 μm than the plane valve plate without bearing pad. Also, the

spherical valve plate could obtain bigger minimum fluid film about $4\ \mu\text{m}$ than the plane valve plate with bearing pad for high pressure range above 20 MPa. Therefore, the minimum fluid film of the spherical valve plate decreased to the lowest rate of the three valve plates.

Figure 14 shows the difference between maximum and minimum fluid film with discharge pressure. In the case of the plane valve plate without bearing pad, the difference abruptly increased with discharge pressure at above 15 MPa. But, in the case of VP2 and VP3, the difference almost increased linearly with all discharge pressure range. As mentioned earlier, these phenomena are also related with the tilting of the cylinder block in high pressure range.

4.3 Comparison of leakage flow rates and total efficiency

Fig. 15 shows the comparison of the leakage flow rates with discharge pressure at 1500 rpm. The leakage flow rates increases as discharge pressure increases. Especially, the leakage flow rates of the spherical valve plate shows the lowest value compared with the other two valve plates in the range above 20 MPa. But, the leakage flow rates of the plane valve plate without bearing pad sharply increases compared with those of the plane valve plate with bearing pad in high pressure range above 25 MPa due to the increase of fluid film.

The comparison of the total efficiency with discharge pressure at 1500 rpm is shown in Fig. 16. For low pressure range below 20 MPa, the efficiency of the plane valve plate without bearing pad is higher than the plane valve plate with bearing pad due to the tiny fluid film. But, for high pressure range above 25 MPa, the efficiency of the plane valve plate with bearing pad was better value than the plane valve plate without bearing pad because the bearing pad reduces the cylinder block from tilting. The total efficiency of the spherical valve plate is the most acceptable of the three valve plates in overall pressure range. Especially, the spherical valve plate maintained good total efficiency in spite of high pressure range.

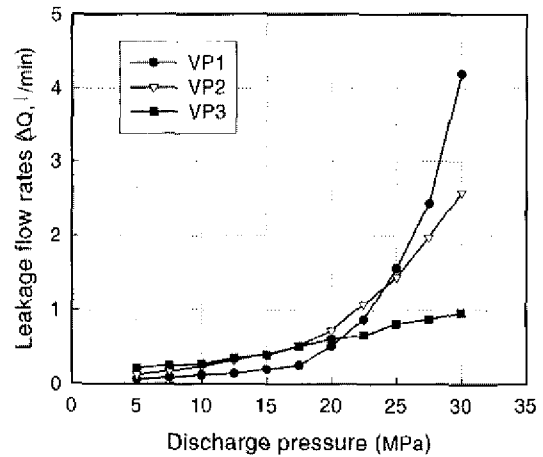

Fig. 15 Comparison of the leakage flow rates

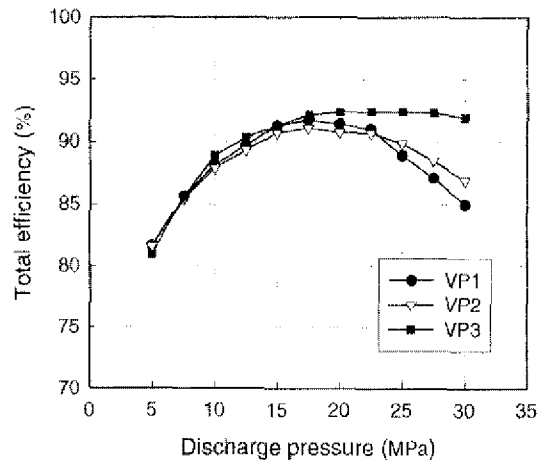

Fig. 16 Comparison of the total efficiency

5. Conclusions

The fluid film thickness between valve plate and cylinder block was measured by using a miniature gap sensor in real driving conditions. Three valve plates were used in the tests in order to investigate the effects of valve shapes. One of the valve plates was the plane valve plate without bearing pad, another plane valve plate had bearing pad, and the third valve plate was a spherical valve plate. Following results were obtained :

(1) The minimum fluid film on the valve plate exists in the discharge region ($\theta=100-135^\circ$) and the maximum fluid film exists in the suction region due to the tilting of the cylinder block.

(2) The bearing pad design in the plane valve plate partly reduced the tilting of the cylinder block in the high pressure conditions due to the hydrodynamic effect at bearing pad

(3) The minimum fluid film thickness of the plane valve plate with bearing pad was $7\ \mu\text{m}$ which is bigger than that of the plane valve plate without bearing pad in the high pressure conditions

(4) The spherical valve plate could remarkably reduced both the shaking and the tilting of the cylinder block over all driving conditions

(5) The minimum fluid film thickness of the spherical valve plate was $4\ \mu\text{m}$ which is bigger than that of the plane valve plate with bearing pad in high pressure conditions

(6) The discharge pressure pulsation, the leakage flow rates and the total efficiency are deeply related to the changing pattern of the fluid film on the valve plate

(7) The spherical valve plate maintained the most desirable tribological conditions and a good total efficiency compared with the plane valve plate over all driving conditions

References

Franco, N, 1961, "Pump Design by Force Balance," *Hydraulics & Pneumatics*, Vo 14, No 11, pp 101~107

Hibbert, G, Lindsay, D V, Shute, N A and Turnbull, D E, 1971, "The Balancing of Piston

and Valve Plate Forces in Axial-Piston Pumps and Motors," BHRA, Paper G2, pp 13~40

Jae-Youn Jung, Jong-Ki Kim, 2003, "Measurement of Fluid Film Thickness on the Valve Plate in Oil Hydraulic Axial Piston Pumps (Part I Bearing Pad Effects)," *KSME International Journal*, Vol 17, No 2, pp 246~253

Jong-Ki Kim, Hyoung-Eui Kim, Jae-Youn Jung, Seok-Hyung Oh and Seok-Hoon Jung 2004, "Relation Between Pressure Variations and Noise in Axial Type Oil Piston Pumps," *KSME International Journal*, Vol 18, No 6, pp 1019~1025

McKeown, J, Milner, D A, Shute, N A and Turnbull, D E., 1966, "Hydrodynamic Factors Affecting the Design of Valve Plates and Thrust Bearings," *Proc. I. Mech. E*, Vol 181, No 1, pp 653~665

Saitchenko, J S, 1950, "Force Balance Conditions of the Valve Plate and Rotor of an Axial Piston Pump," *Stanki I Instrument*, 10, pp 28~29 BHRA T 750

Shute, N A and Turnbull, D E, 1964, "The Hydrostatic Pressure Distribution Across the Lands of a Valve Plate of an Axial Piston Machine, Part I No Heat Loss," BHRA Rept RR 795

Taylor, R and Lin, L, 1984, "The Application of Tribological Principles to the Design of the Valve Plate of an Axial Piston Pump, Part I," *The BFPR Journal*, Vol 17 No 2, pp 257~262